

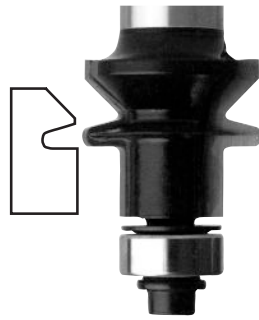

# WAINSCOTING BEAD BOARD BITS

## **STEP 1**

Run grooved bit first. Important: the grooved stock will be your set up block for the tongue bit.



## **STEP 2**

Depth of cut is variable. The top of the bead can be set near the stock surface for 3/8" stock or up to 3/32" below the surface for 5/8" stock.

## **STEP 3**

To set up the tongue bit, take a piece of the grooved stock and set it next to the tongue bit. Adjust the bit height till the horizontal flat section of the bit is equal to the flat section on the bit.

## **STEP 4**

Make a test run and tweak bit height till stock surfaces align perfectly.

## **STEP 5**

To place bead on tongued stock, adjust beading bit height and depth until the lower point of the bead cutter just matches the root of the tongue.

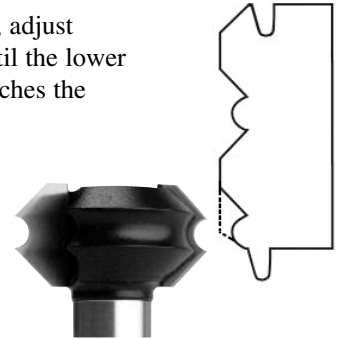

## **STEP 6**

If bead is desired in the center of the board, adjust depth and height as needed.

