

# ADJUSTABLE PLYWOOD TONGUE & GROOVE ASSEMBLIES

1. Assemble cutters to arbor right side up to ensure proper cutting. Cutters put on backwards or upside down will not cut but rather burn the wood and may cause serious injury.
2. Make sure arbor nut is always tightly secured.
3. Always run test pieces to ensure proper spacing alignment. The number of spacers and shims you use and placement may vary depending upon how much room you want for glue and variations in tongue & groove dimensions. Extra spacers and shims are provided for convenience.
4. Start by using 2 thin shims as shown, add extras to achieve desired thickness. (\*)
5. To reduce possible tear outs, always cut "end-grain" before cutting "with the grain" where applicable.

## SET-UP FOR CUTTING TONGUE

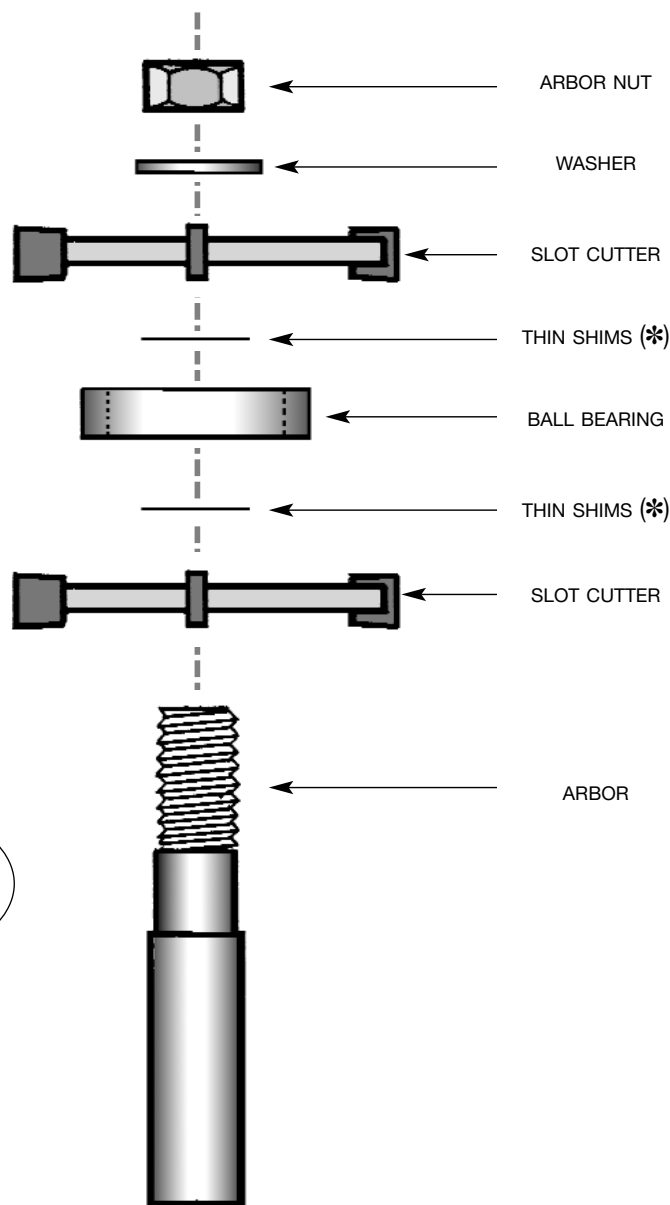

**NOTE:**  
*Additional Shims  
Included*