

Weather Station

Observe and record the weather with your own multi-functional weather station. The kit features a wind vane, an anemometer, a thermometer and a rain gauge. Also experiment with the greenhouse effect and growing plants in a bottle.

A. SAFETY MESSAGES

To Parents: Read all instruction before provide guidance to your children.

1. Please read through these instructions before you start.

2. Adult supervision and assistance are required at all times.

3. Intended for children of over ages 8.

4. This kit and its finished product contain small parts which may cause choking if misused. Keep away from children under 3 years old.

5. Handle the thermometer with care. The glass body is fragile. Broken glass may cause injury. In case the thermometer is broken, contact our customer service for a replacement.

B. CONTENTS

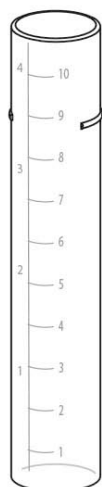

Plastic tube

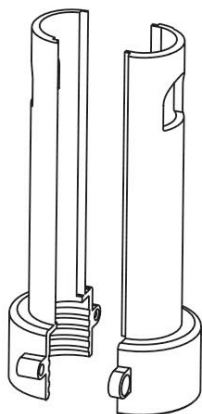

2 halves of support column

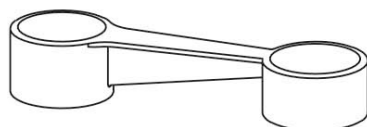

rain gauge support arm

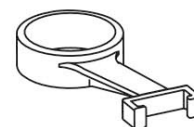

thermometer support arm

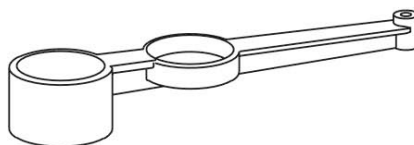

wind vane support arm



long spindle

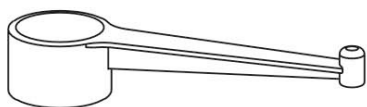

anemometer support arm



short spindle



thermometer



funnel



wind vane



compass



cap



anemometer cups



anemometer hub



screws

B. CONTENTS

Also required but not included: 0.5-litre or 1-litre plastic soda bottle with screw thread and small crosshead screwdriver.

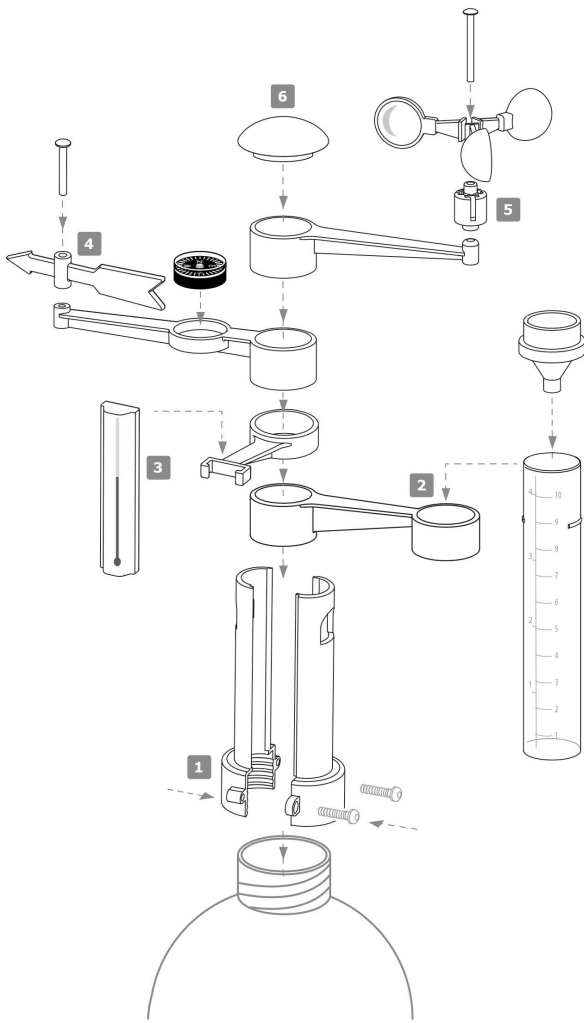

C. ASSEMBLY

Follow these steps to assemble your Weather Station. Coloured numbers refer to the diagrams.

1. Put the two halves of the support column together and secure them with two screws. Screw the column onto the neck of an empty, clean soda bottle.
2. Now assemble the rain gauge section of the weather station. Identify the rain gauge support arm. The flat side of the arm is the top side (note that the top side of each arm is the flat side). Slide the plastic tube through the hole at the narrow end of the arm until it stops. Push the funnel firmly into the top of the tube.
3. Now assemble the thermometer section. Identify the thermometer support arm. Slide the thermometer down into the brackets on the end of the arm until it stops. Note that the thermometer's bulb should be at the bottom.
4. Next, assemble the wind vane section. Identify the wind vane support arm. Push the compass into the hole in the centre of the arm. Push the shorter spindle through the hole in the wind vane and into the hole in the end of the arm. Check that the vane spins freely.
5. Finally, assemble the anemometer section. Identify the anemometer support arm. Slot the three cups into the hub, making sure that they all point in the same direction (all clockwise or all anticlockwise). Push the longest of the two spindles through the hub and into the small hole in the end of the support arm. Check that the anemometer spins freely.
6. Now place the four instrument arms onto the support column. Put the rain gauge on first, followed by the thermometer, then the wind vane and the anemometer. Finally, put the cap on top of the column. Congratulations! Your weather station is complete.

D. HOW IT WORKS

Your weather station is designed to measure wind, rainfall and temperature.

The anemometer and wind vane measure the wind. The cups of the anemometer catch the wind and make the anemometer spin. The faster it spins, the higher the wind speed. This anemometer cannot tell you exactly what the wind speed is. The wind vane points in the direction that the wind is blowing from. You can look at the compass and estimate which way the arrow on the wind vane is pointing.

The compass contains a magnetized metal disc. Its magnetic poles are lined up with the N and S letters, which show north and south. The disc spins so that the poles point towards the Earth's magnetic poles, which are near the Earth's geographic poles.

The rain gauge measures how much rain has fallen. The funnel catches the rain and helps to stop the water in the tube from evaporating. You can measure the rainfall by reading the markings on the tube.

The thermometer measures air temperature. The special liquid inside the bulb expands when it heats up, which makes it reach further up the tube, showing a higher temperature. The liquid contracts again when it cools.

Date	Temperature	Rainfall	Wind strength (Calm/ Light/ Breezy/ Strong)	Wind direction	Remarks

D. OPERATION

1. Unscrew the bottle from the rest of the weather station. Fill it about two-thirds full with water.
2. Now find a suitable site for your weather station. It should be in an open site, not sheltered from the wind, and not under the cover of trees. Stand the station on a flat, firm surface. Turn it so the thermometer is facing north (this will stop the sunlight hitting the bulb, which would give false readings of the air temperature).
3. Take readings from the instruments once a day. Always take the readings at the same time of day so that you can compare one day's weather to the next. Here's how to take readings:
 - Rain gauge: remove the tube from its holder, hold it vertical and measure the rainfall by reading the marking on the cylinder. Write down your reading. Then remove the funnel and shake the water out. Replace the funnel and replace the tube in its holder.
 - Thermometer: read the number (either in degrees Celsius or degrees Fahrenheit) next to the top of the red line. Write down the reading.
 - Anemometer: the anemometer does not have a scale to read, but by watching it, you can estimate if the wind is calm, light, breezy or strong. Write down your estimate.
 - Wind vane: look at the compass and estimate which way the arrow on the wind vane is pointing (N, W, SE, and so on). Write down the reading.
4. In a notebook, make a table with one line for each day and six columns, one for the date and one each for rainfall, temperature, wind strength, wind direction and remarks.
5. Compare your finding with those of the local observatory to see how accurate your records are.
6. You could try making a record of how the weather changes over a day. Record the findings every hour. Write down the times and readings in a table.

E. TROUBLE SHOOTING

- **If the anemometer or the wind vane do not spin freely, they may be trapped by their spindles. Pull the spindles up slightly to free the anemometer or wind vane. You may also polish the spindles with a sand paper or add a bit cooking oil as lubrication.**
- **If the weather station topples over, add some more water, and make sure the bottle is standing on a flat surface.**
- **If the compass is not turning freely, give it a gentle tap.**
- **If the rain gauge does not fill up during rain, make sure that is not sheltered under one of the other arms.**

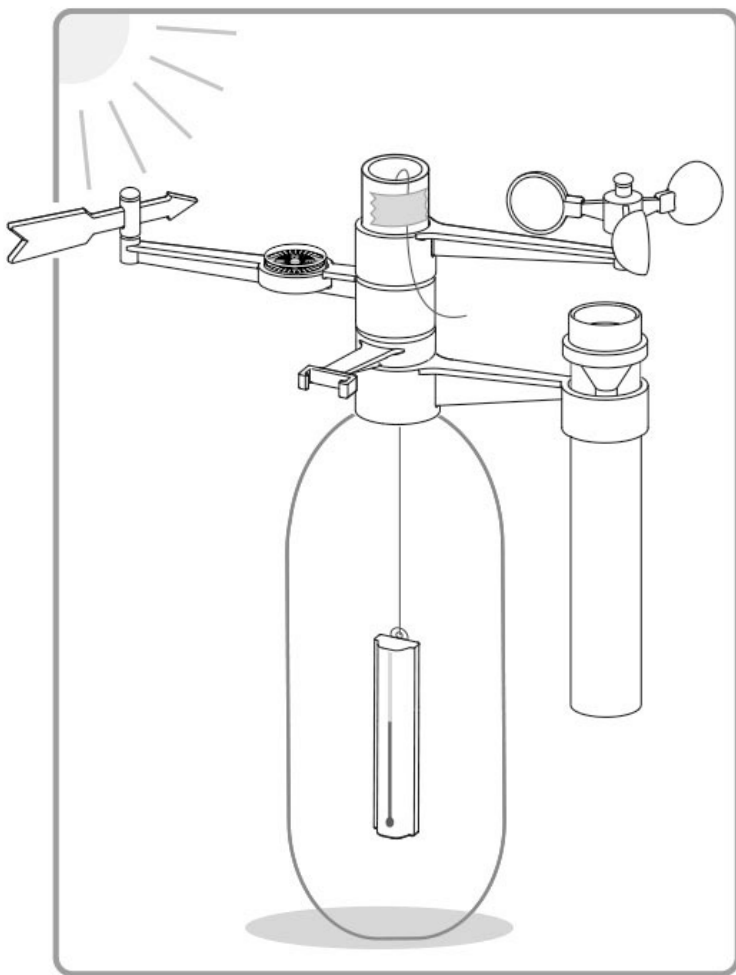

G. MORE EXPERIMENTS TO DO

Green House Effect

- On a sunny day, you can test the greenhouse effect with the bottle. Pour the water from the bottle and stand the weather station in a sunny spot for a few minutes. Note the temperature on the thermometer, then remove the thermometer from its support arm. Remove the cap from the support column. Attach a piece of thread to the thermometer, and lower the thermometer into the bottle for a few moments. Take the thermometer out and read it again. You should find the reading has gone up. This is because the bottle has trapped some heat from the Sun, which has warmed the air inside.
- The plastic bottle traps heat from the Sun. Heat rays from the Sun go into the bottle, heating the air inside, but heat rays from inside cannot escape. This effect is called the greenhouse effect, because it is how greenhouses trap heat.
- Gases in the Earth's atmosphere trap heat in a similar way to the plastic bottle. Carbon dioxide is one of the gases. Burning fuels such as petrol and gas is adding carbon dioxide to the air, which is increasing the heat that is trapped. This is known as global warming.
- Global warming is changing the Earth. Climates (patterns of weather) are slowly changing, and the rising temperature is making ice at the poles melt. In the future, global warming may bring more extreme weather events, such as hurricanes and floods.

Weather Station Terrarium

- You can grow plants inside the bottle. For this you will need some potting compost, some gravel, and some indoor plants (such as small ferns, ivy or spider plants). Unscrew the bottle from the weather station. Ask an adult to help you cut off the top third of the bottle with scissors or a craft knife. Put about 2 centimetres of gravel into the bottom of the bottle, and then fill the bottle about a third full with potting compost. Carefully push the roots of one or two plants into the soil and press down the soil around them. Replace the top of the bottle and stick it in place with some waterproof tape, and replace the weather station. Cover the holes in the top of the central column with some sticky tape. Place your bottle in a well-lit place, but not in direct sunlight. Your plants should grow without having to water them.
- The mini garden you have made inside your bottle is called a terrarium. It does not need to be watered because water vapour given out by the plants forms drops on the bottle's insides, which runs back down into the soil.
- The terrarium also demonstrates the water cycle. This is the circulation of water between the oceans, the atmosphere and the land. Water evaporates from the oceans and the soil, forms clouds and also rain, which falls onto the land, and then flows back along rivers to the ocean. In the terrarium, water evaporates from the soil and from the plant leaves. It condenses on the inside of the bottle (this represents clouds). Then it runs back down into the soil (which represents rain).

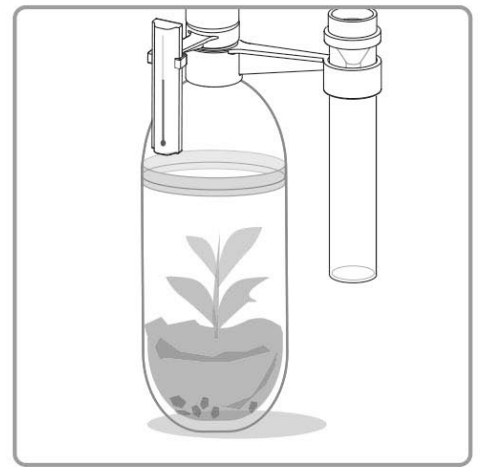
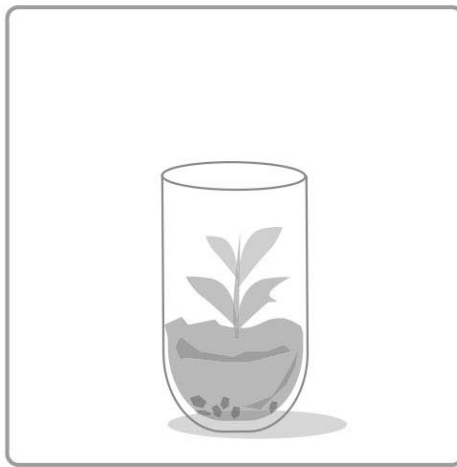

H. FUN FACTS

- Weather stations are important for weather forecasting. Data from weather stations all over the world helps forecasters to see patterns in the weather, which helps them to forecast what is likely to happen in the next hours and days.
- Automatic weather stations, powered by solar panels, send readings from their instruments by telephone or radio to the offices of weather-forecasting organisations.
- Most weather stations have a maximum and minimum thermometer, which records the highest and lowest temperatures during a 24-hour period.
- The record for the highest temperature is sizzling 57.8°C, recorded in Libya. The lowest temperature is a freezing -89.2°C, recorded in Antarctica.
- In 1970, 38 millimetres of rain fell in one minute during a storm in Guadeloupe.

I. QUESTIONS & COMMENTS

We treasure you as a customer and your satisfaction with this product is important to us. In case you have any comments or questions, or you find any parts of this kit missing or defective, please do not hesitate to contact our distributor in your country, whose address is printed on the package. You are also welcome to contact our marketing support team at Email: infodesk@4M-IND.com, Fax (852) 25911566, Tel (852) 28936241, Web site: WWW.4M-IND.COM